

# AMESim

## LIBRARIES – THERMAL HYDRAULIC

### Overview

Heat exchanges occur in most industrial processes either because they are expected (ovens, heat exchangers...) or unavoidable (thermal shocks, thermal losses, friction...). These exchanges are likely to occur through moving fluids or between moving fluids and the environment as soon as temperature differences are encountered.

The AMESim® Thermal-Hydraulic library is dedicated to the design of hydraulic systems in which variations of fluid temperature have a great influence on the overall behavior. Made of over 100 models of various complexity levels, this library is based on a transient heat transfer approach, used to model thermal phenomena in liquids (energy transport, convection) and to study the thermal evolution of these liquids in a hydraulic circuit.

### KEY POINTS

- Steady-state and transient simulation.
- Graphical interface enables you to create new designs quickly.
- State-of-the-art theory. Easy parameters filling from manufacturers' experiments or data from technical drawings.
- Recognizable technological icons facilitating direct model correlation with technical drawings.
- Full multi-domain compatibility for total system analysis with study of energetic couplings.
- Complex modeling without writing a single line of code thanks to a Basic Element approach.
- Build and save your own models for easy reuse.
- Sensitivity analysis and size optimization.
- Time domain and frequency analysis for vibration modes characterization (eigenvalues, modal shapes, transfer functions).
- Matlab®/Simulink® interface for control design.
- Direct integration of your own C and Fortran code.
- Fully compatible with other AMESim libraries.

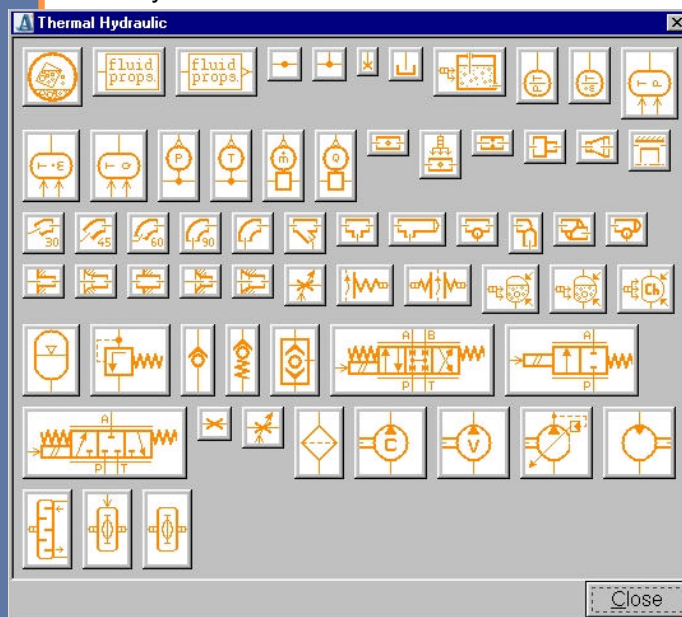

### Benefits

The user-friendly AMESim Thermal Hydraulic library helps you to efficiently develop new design concepts. Thanks to a large collection of thermal-hydraulic components, it allows the user to find out the right answers for the optimal development of complex thermal-hydraulic systems. As a result, the customer cuts down on the number of prototypes, and reduces both the development cost and the time to market.

Models of hydraulic systems are numerically stiff, extremely non-linear and are often modeled with discontinuities. The unrivaled AMESim solver automatically and dynamically selects the most adapted integration method based on the particular system dynamics better than any other software on the market.

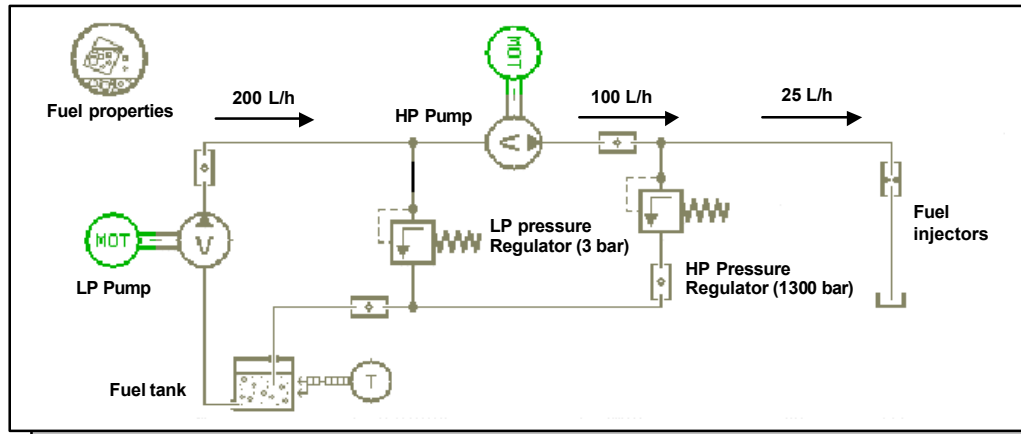

*A fuel circuit model in which temperature is evaluated.*

## Features

The AMESim environment and Thermal-Hydraulic library offer a large number of capabilities such as:

- Many standard components included (pumps, valves, actuators...).
- Compressible fluid consideration with rigorous treatment of fluid properties as a function of working pressure and temperature. Conservation of mass, momentum and energy.
- One or more fluids in one system model.
- Includes effects of cavitation, air release and viscosity.
- Severe non-linearities and discontinuities are seamlessly handled.
- Calculation of all the required variables (mass and enthalpy flow rates, pressures, temperature...) accessible during or after computation.
- Water hammer transients with advanced pipe models.
- Modular heat exchanger models.
- Hydraulic network analysis.

## Requirements

The AMESim Thermal Hydraulic library runs on Unix®, Linux® platforms and Pentium®-based PCs.

The AMESim Thermal library is recommended.

## Thermal Hydraulic models

- Thermal-Hydraulic fluid properties.
- Fluid property sensors.
- Nodes, plug, tank.
- Pressurized tank with variable height of liquid.
- Ideal and modulated pressure and flow sources.
- Signal to thermal-hydraulic port converters.
- Pressure, temperature, flow rate sensor.
- Pipe with/without external heat exchange.
- Restriction.
- Sudden and progressive expansion/contraction.
- Bends: 45, 60, 90 deg general.
- T-junctions: 45, 90 deg.
- Intersecting holes: 90/180 deg, 2 and 3 ports.
- Intersecting holes: 90 deg, 2 ports, intersecting and non-intersecting axes.
- Volume connected to pipe: sharp, rounded, extended, 60/90 conical entry.
- Convection with one/two thermal ports.
- Volume containing gas and liquid.
- Volume with compressibility and thermal port.
- Accumulator.
- Relief, check and shuttle valves.
- Electrically operated 2, 3 and 4 port valves.
- Constant and modulated orifice.
- Filter.
- Volumetric and centrifugal pump.
- Pressure regulated pump.
- Fixed displacement hydraulic motor.
- Heat exchangers.

**IMAGINE**  
www.amesim.com

Contact IMAGINE directly:

USA: +1 734 207 5557  
 UK: +44 18 69 351 994  
 France: +33 (0)4 77 23 60 30  
 Germany: +49 89 548 495 0  
 China: +86 13818750986  
 Japan: +81 (0) 3 3351 9691

E-mail: [info@amesim.com](mailto:info@amesim.com)

Visit [www.amesim.com](http://www.amesim.com) to obtain contact information for authorized IMAGINE representatives in other countries.