



APPLICATIONS – Aerial Work Platforms

KEY POINTS

- Steady state and transient simulation.
- State-of-the art for aerial work platform system modeling.
- Time domain and frequency analysis tool:
 - Vibration modes characterization
 - Eigenvalues and Bode response
 - Activity index for energy/efficiency
- Fluid properties database for a large range of pressures and temperatures.
- Built-in database of parameters for handy modeling.
- Accurate flow considerations (laminar/turbulent).
- Advanced hydraulic line models (wall compliance, frequency dependent friction...).
- Electronic Control Unit integration
- 2D planar mechanisms direct representation.
- Easy integrated comparison with experiments.
- Reduce your costs and enhance your supplier relations by the re-use of secured hydraulic models.
- AMESim, the simulation environment to improve
 - Functionality & safety (legislation)
 - Performance
 - Efficiency (Energy, Weight)
 - Dynamic Behavior
 - Controllability
 - Customizability

Photo: Imagine



OVERVIEW

AMESim[®] allows you to design and optimize an aerial work platform concept (Boom lift or scissors) early in the process. It offers an open architecture for various configuration.

The dynamic behaviour of such a system is hard to predict since every sub-system needs to be taken into account.

For early prototyping, it is inefficient to use highly sophisticated and specific software in coupling them together: lack of compatibility, implementation time of the integration method chosen, interface difficulties between software, programming effort, poor numerical convergence...

A new step in mobile hydraulic has been taken by using AMESim, the most efficient tool to answer typical concerns such as sizing of your system, optimization of your network architecture, development of control strategies, increasing component performance, reduction of flow ripples, damping of pressure fluctuations, reduction of energy consumption, increase of efficiency, study of air release or behavior at cold start, analysis of oscillations due to rope effects, understanding of wear and stress due to hydraulic / mechanical couplings, test of different load case situations and working processes...

With this new combination of hydraulics & 2D mechanics in one physical modeling environment, IMAGINE provides a speedy, easy, secure & optimal way for the design of hydraulically actuated platforms.

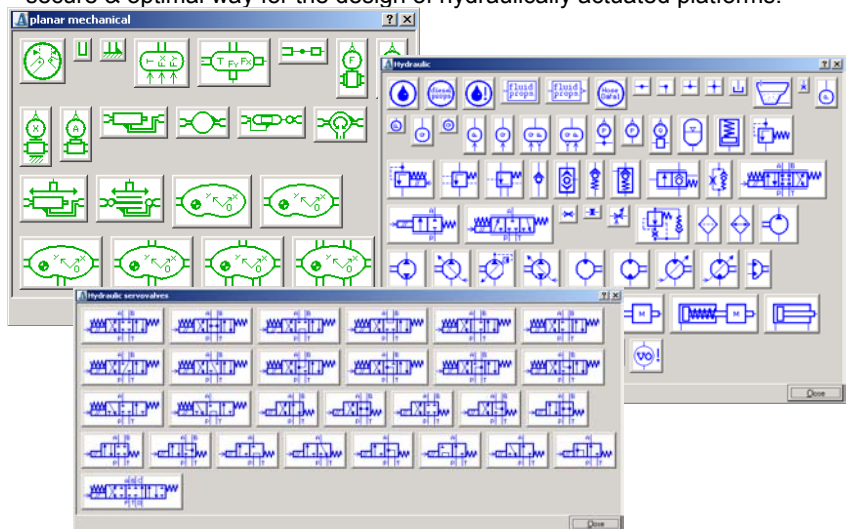

Applicable libraries

- **AMESim Mechanical** library
- **AMESim Control** library
- **AMESim Hydraulic** libraries
- **AMESim Electric Motors and Drives** library.
- **AMESim 2D-Mechanical** library (available 2004).

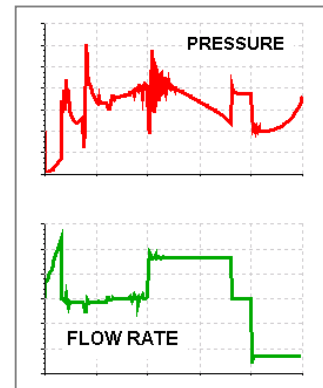
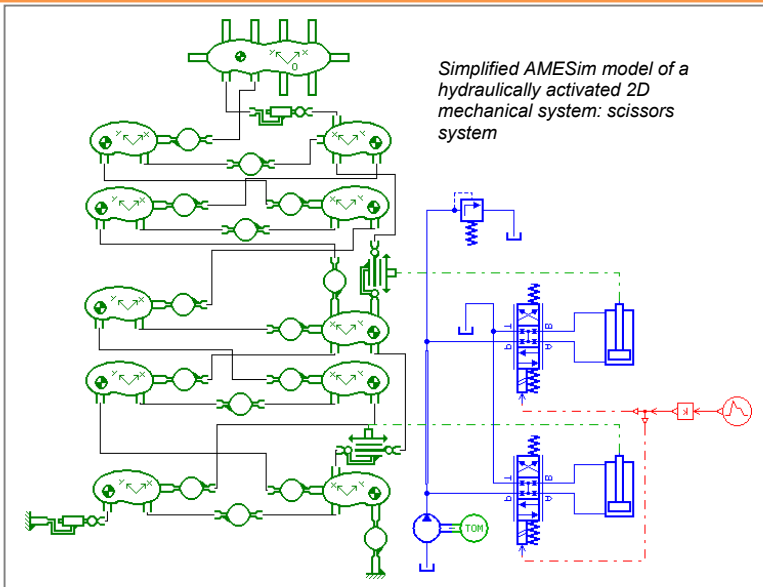

Performance

Models reliability and accuracy are demonstrated through permanent comparison with experimental data for various operating modes, different supply pressures and load considerations.

Simulation results are so predictive that AMESim may be used to control the industrialization process and to determine where to save money with manufacturing considerations by doing model sensitivity analysis.

Unrivaled capabilities

Models of multi-domain systems are numerically stiff, extremely non-linear and often modeled with discontinuities. The unrivaled AMESim solver automatically and dynamically selects the most adapted integration method based on the particular system dynamics better than any other software on the market.

Linear analysis allows you to access the system's intrinsic dynamical properties no matter the inputs. The linear model is simpler to analyze than a non-linear model and quicker with almost null CPU time. It is the most powerful tool when excitations are periodic: pump flow ripples, PWM controlled pressure regulator...

Benefits

AMESim facilitates the development of new concepts and the finding of answers to challenges such as efficient powerful systems or low-maintainability machines.

System development time is reduced significantly (from months to weeks). The maintainability of the models means that the system lifespan is increased whilst system costs are reduced. Application libraries are constantly evolving thus ensuring that the correct models are always available even in this changing industrial world.

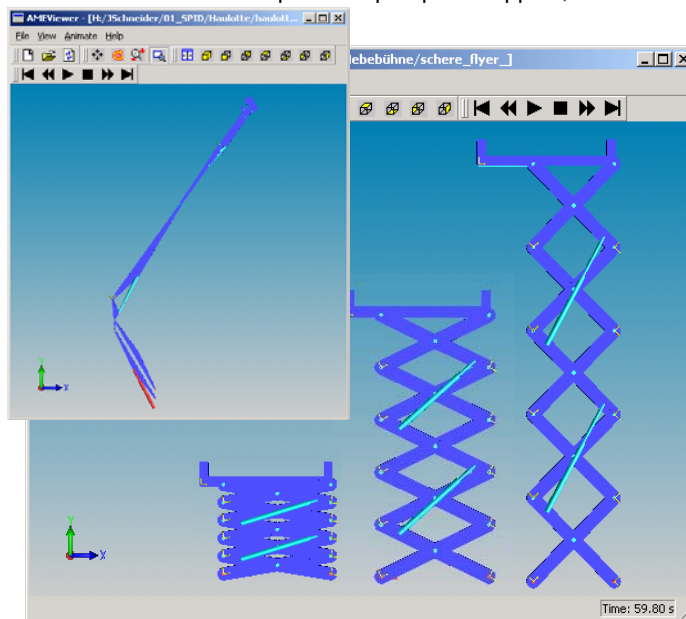

3D Visualization

AMESim facilitates the visualization of the load crane system with AMEViewer, a 3D Visualization Tool, which automatically generates a 3D System from your AMESim Model and allows animation of the simulation results.

AMEViewer is a very important tool for the visualization of vibration as well as for internal and external communication and also for the global understanding of your loader crane system.

2003 new references in mobile hydraulics

AMESim is successfully used for the design of mobile hydraulic equipments such as Bosch Rexroth, Oil Control, Casappa, HAWE Hydraulik, HYDAC, Hytos, Innas BV, JCB, Poclain Hydraulics, Volvo, Komatsu, Liebherr.

IMAGINE
www.amesim.com

Contact IMAGINE directly:

USA: +1 734 207 5557
UK: +44 18 69 351 994
France: +33 (0)4 77 23 60 30
Germany: +49 89 548 495 0
China: +86 13818750986
Japan: +81 (0) 3 3351 9691

E-mail: info@amesim.com

Visit www.amesim.com to obtain contact information for authorized IMAGINE representatives in other countries.